

# High Performance End Launch Connector

## Part No: G02SFB002

www.gigalane.com



GigaLane High Performance End Launch Connectors are designed for 2.4mm (50 GHz), 2.92mm (40 GHz) and SMA (27 GHz) with Low VSWR. It is easily connected to GPCW transmission line and microstrip line.

### ► Specification

#### Electrical

Frequency	2.92mm DC ~ 40 GHz
Impedance	50 Ω
VSWR	1.57 : 1 (-13dB)
Insulation Resistance	Low Insertion Loss

#### Materials

Connector	Body	Stainless Steel (Passivated)
	Center Contact	Beryllium Copper (Gold Plated)
	Insulator	Engineering Plastic
Launch Block	Launched Block	Brass (Ni Plated)
	Pin	Beryllium Copper (Gold Plated)
	Insulator	PTFE

#### Environmental

Thermal Shock	MIL-STD-202, Method 107, Condition B
Corrosion (salt Spray)	MIL-STD-202, Method 101, Condition B, 5% salt
Shock	MIL-STD-202, Method 213, Condition I
Vibration	MIL-STD-202, Method 204, Condition D
Moisture Resistance	MIL-STD-202, Method 106

### ► Drawing

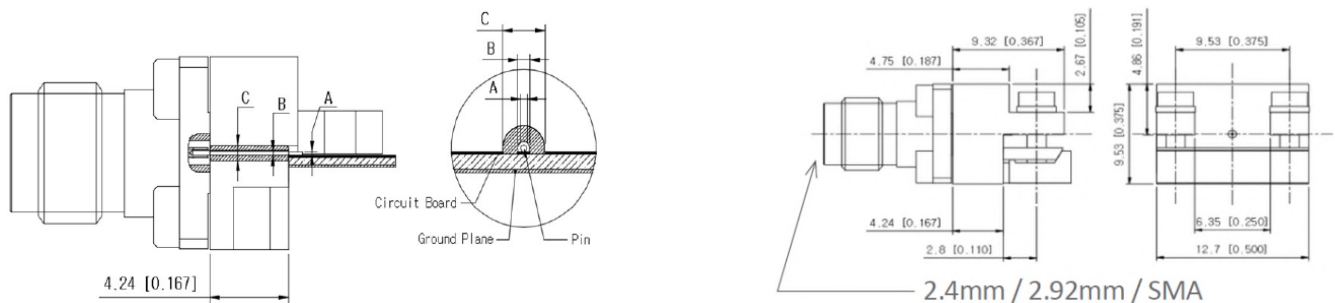

Unit : mm [inch]

Part No.	Pin Diameter		Dielectric Diameter
	A	B	C
G02SFB002	0.18 [0.007]	0.30 [0.011]	0.93 [0.036]

# High Performance End Launch Connector

## Part No: G02SFB002

www.gigalane.com

### ► Installation Procedure

- Mount the end launch connector on the board in the desired position.
- Make sure the launch pin is at the center of the trace.
- Make sure the launched block is tight against board.
- Tighten the M1.6(1.5mm) mounting screws to be tighten unit the connector is secured.

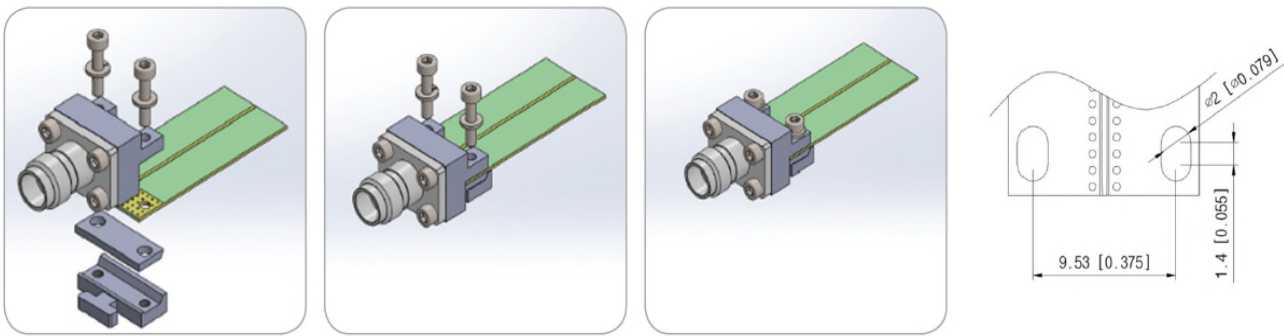

### ► GCPWG Test Result of G02SFB002

### ► Microstrip with Top Ground Test Result of G02SFB002

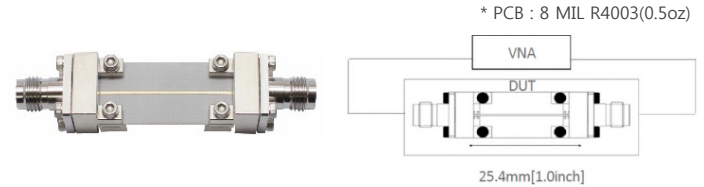
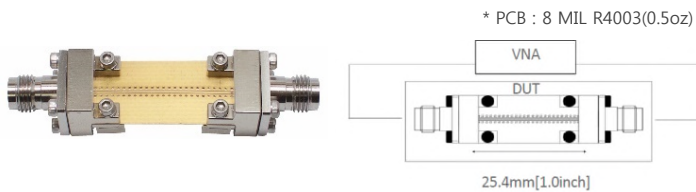

Specification	Test Result
Insertion loss : Min -3.7dB @ 0.1~40GHz	Insertion loss : Min -3.3dB @ 0.1~40GHz
Return loss : Max. -13dB @ 0.1~40GHz	Return loss : Max. -14.9dB @ 0.1~40GHz

Specification	Test Result
Insertion loss : Min -3.7dB @ 0.1~40GHz	Insertion loss : Min -2.6dB @ 0.1~40GHz
Return loss : Max. -13dB @ 0.1~40GHz	Return loss : Max. -14.0dB @ 0.1~40GHz

